

Tel: (212) 279-3878

TED STEEL INDUSTRIES LTD

SPEED RAIL AND GARMENT RACKS
STEEL PARTITION AND SHELVING

361 W. 36th Street
New York, NY 10018

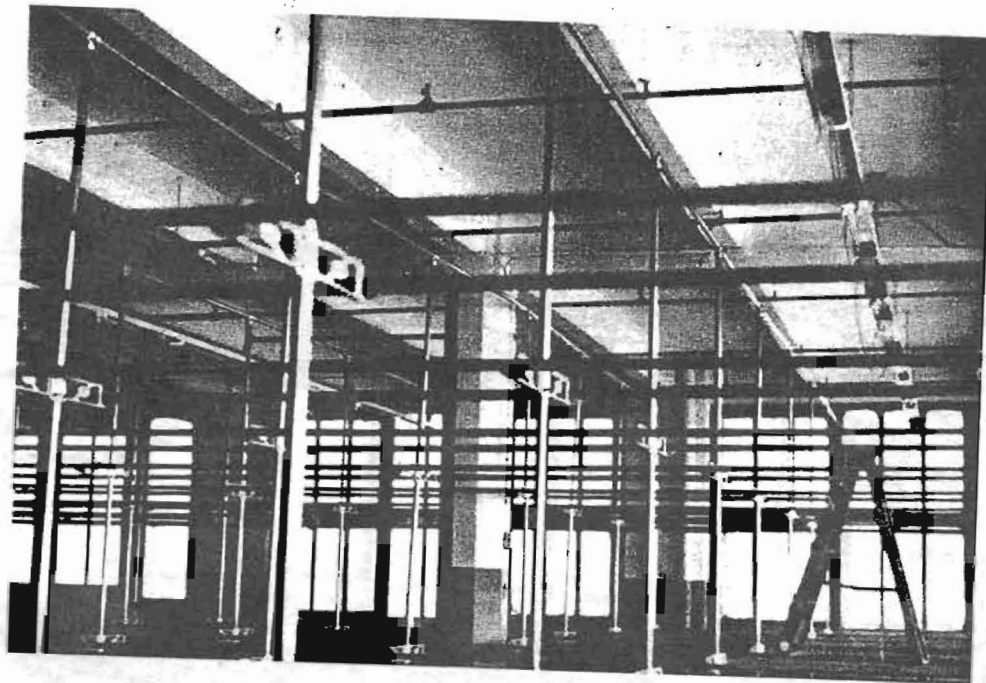
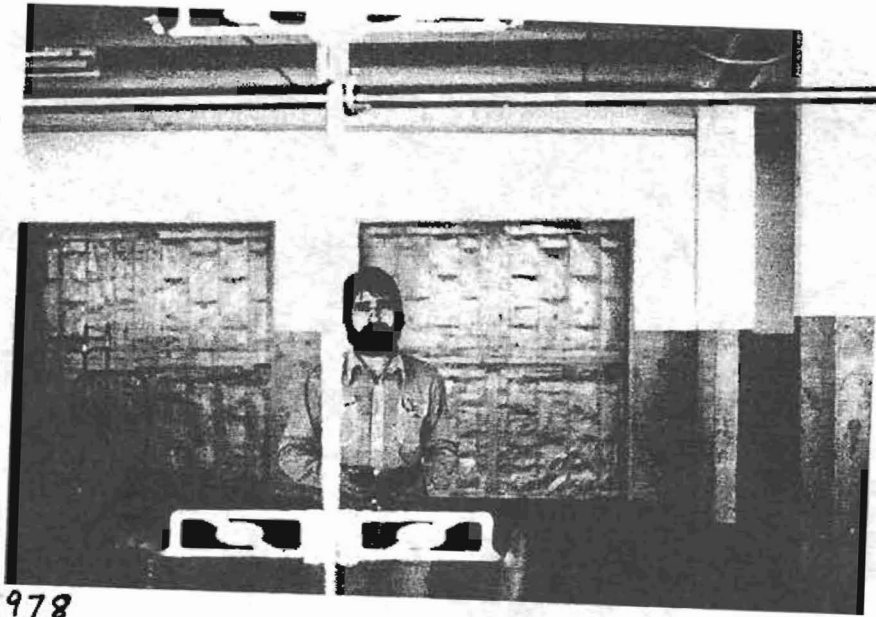

POST

3'3"
 4'3"
 5'3"
 6'3"
 7'3"
 8'3"
 9'3"
 10'3"
 11'3"
 12'3"
 13'3"
 14'3"

RE BARS

24"
 30"
 36"
 42"
 48'

PERF. FLATS

3'3"
 4'3"

SHELVES

12x24
 12x30
 12x36
 12x42
 12x48
 15x24
 15x30
 15x36
 15x42
 15x48
 18x24
 18x30
 18x36
 18x42
 18x48
 24.24
 24x30
 24x36
 24x42
 24x48
 30x30
 30x36
 30x42

30x48
 36x36
 36x42
 36x48
 42x42
 42x48

PREF SHELVES

EXTRA***

SWAY BRACES

9"
 12"
 15"
 18"
 21"
 24"
 30"
 36"
 42"
 48"

BOLTS per 100

5/8"
 1"

LABEL HOLDER

30"
 36"
 42"
 48"

BACK & SIDES

12x3'3"	24x10'3"
12x4'3"	36x3'3"
12x5'3"	36x4'3"
12x6'3"	36x5'3"
12x7'3"	36x6'3"
12x8'3"	36x7'3"
12x9'3"	36x8'3"
12x10'3"	36x9'3"
18x3'3"	36x10'3"
18x4'3"	42x3'3"
18x5'3"	42x4'3"
18x6'3"	42x5'3"
18x7'3"	42x6'3"
18x8'3"	42x7'3"
18x9'3"	42x8'3"
18x10'3"	42x9'3"
	42x10'3"
	48x3'3"
	48x4'3"
	48x5'3"
	48x6'3"
	48x7'3"
	48x8'3"
	48x9'3"
	48x10'3"
24x3'3"	
24x4'3"	
24x5'3"	
24x6'3"	
24x7'3"	
24x8'3"	
24x9'3"	

5

SPECIAL

Sizes add

BASES & BIN FRONTS

- 2x15
- 2x18
- 2x24
- 2x30
- 2x36
- 2x42
- 2x48

DIVIDERS

- 6x12
- 6x15
- 6x18
- 8x12
- 8x15
- 8x18
- 10x12
- 10x15
- 10x18
- 12x12
- 12x15
- 12x18
- 14x12
- 14x15
- 14x18
- 16x12
- 16x15
- 16x18

ALL RACKS INDUSTRIES, INC.

SPEED RAIL AND GARMENT RACKS
STEEL PARTITION AND SHELVING

325 WEST 38TH STREET
NEW YORK, N. Y. 10018

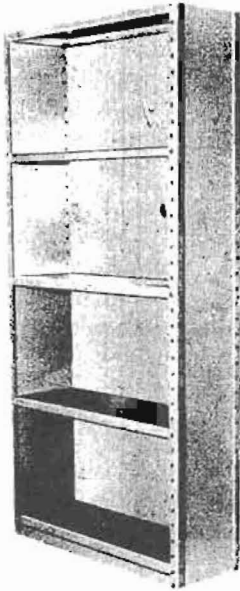

**STANDARD
ENCLOSED UNIT**

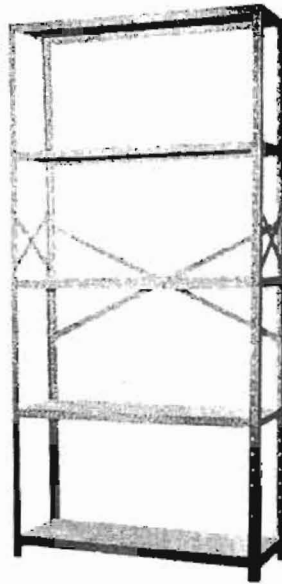

SKELETON

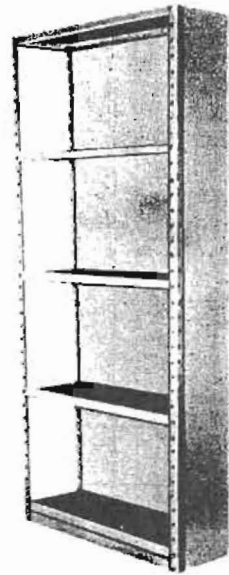

**STANDARD UNIT WITH
BACK and SIDE**

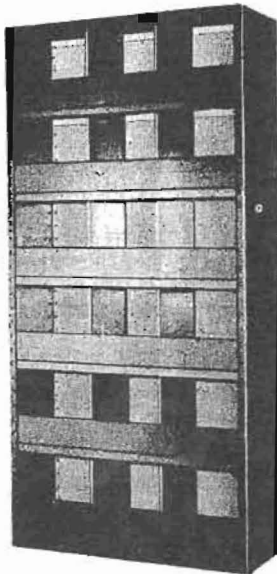

**PART BIN WITH
BIN FRONTS**

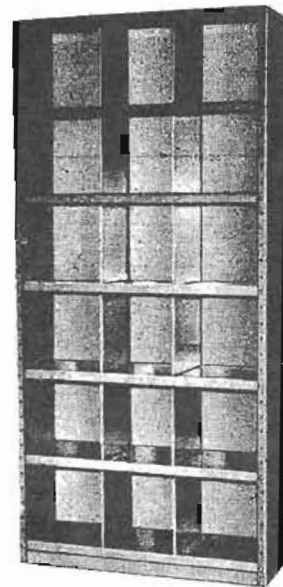

PART BIN

ALL RACKS INDUSTRIES

Garment Racks - Steel Shelves
Speed Rail & Partition
(212) 244-1069

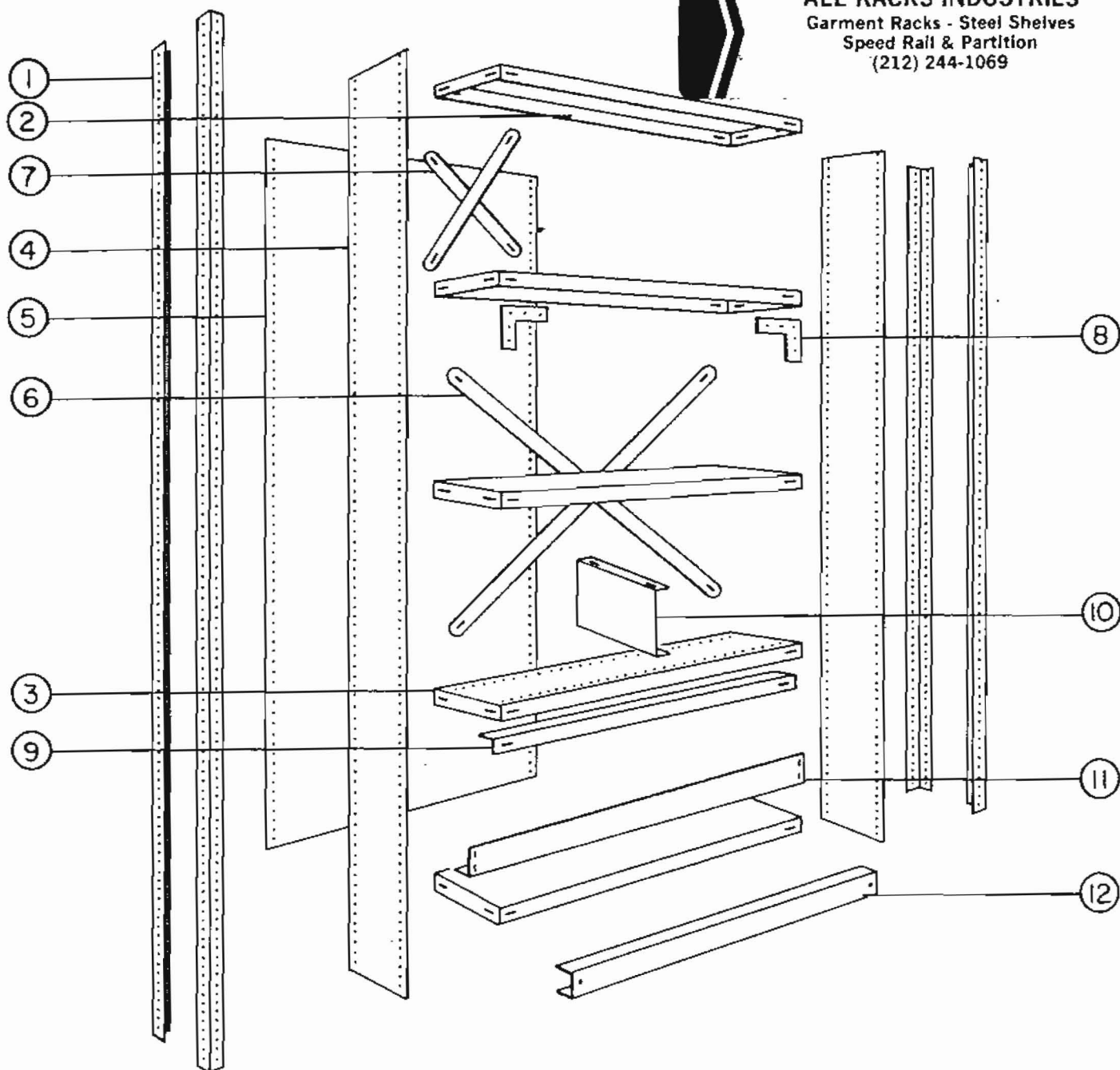

1. POST:

Roll formed 12 gauge rail steel angle upright $1\frac{1}{4} \times 1\frac{1}{4}$ with holes punched on both legs 1" on center for vertical adjustment of shelves. Lengths of 3'3", 4'3", 4'3", 5'3", 6'3", 7'3", 8'3", 9'3", 10'3", 11'3", 12'3".

2. SHELF:

Formed into channel shape with vertical and two return flanges on all four sides (triple Bend) for added strength. Stock sizes are 24", 30", 36", 42", 48" wide, depths of 9", 12", 15", 18", 24", 30", 36". Special sizes are also available.

3. PERFORATED SHELF:

Shelves are punched on 1" centers to accommodate shelf dividers. Stock sizes are the same as above.

4. SIDE PANEL:

Used on closed type shelving. One panel may be common to two adjacent units. (Sides over 4'3" consist of overlapping pieces.)

5. BACK PANEL:

Used on closed type shelving. One panel may be common to back to back units. (Backs over 4'3" consist of overlapping pieces.)

6. BACK SWAY BRACE:

Used on open type shelving to prevent lateral sway and add rigidity.

7. SIDE SWAY BRACE:

Used on open type shelving for added rigidity.

8. ANGLE SWAY:

Used in place of sway braces when unobstructed entry is required.

9. REINFORCEMENT ANGLE:

12 Gauge Rail Steel angle snaps into flange of shelf. Used to prevent deflection of heavily loaded shelf.

10. SHELF DIVIDER:

Used to divide shelf into bin compartments. Attaches to shelves with clips or nuts and bolts.

11. BIN FRONT:

Prevents small items from rolling out of bins. Attaches to upright post.

12. BASE STRIP:

Prevents litter from accumulating under shelf, adds strength to bottom shelf.

FINISH:

Durable baked-on gray enamel. Other colors available on request.

Terms: Net
FOB Warehouse

Monorail Racking Systems

Prices Subject to Change
Without Prior Notice

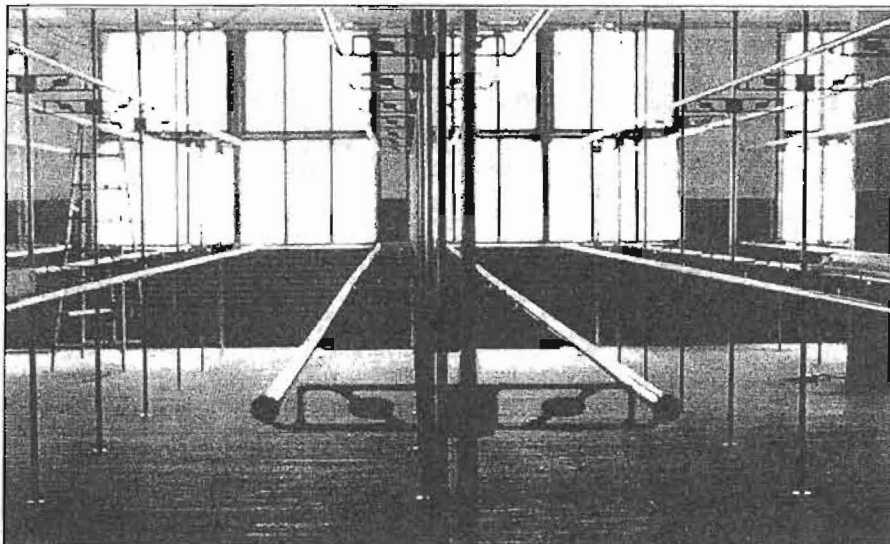

Ideal for Maximizing Storage Capacity in
Warehouse/Factory Store/ Storeroom/Showroom in
Galvanized or Chrome Tubing

The New Industrial Hi-Tech Look

Expert Installation from Small Spaces in Stores
and Showrooms to Large Warehouse
and Factory Systems

CALL FOR AN APPOINTMENT OR FAX US YOUR
LAYOUT. WE WILL PROVIDE A FREE ESTIMATE.

NO JOB TOO
BIG
OR TOO
SMALL

For Store and
Showroom Connectors
see Page 10.
For Chrome Plated
Tubing see Page 23.

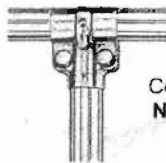

3-Way Connector
Connects 1" to 1" Tubing
No. ZC311 ea.
Connects 1 1/4" to 1 1/4" Tubing
No. ZC3125125 ea.
Connects One 1 1/4" Tube
to 1" Tubing
No. ZC31251 ea.
Connects One 1" Tube
to 1 1/4" Tubing
No. ZC31125 ea.

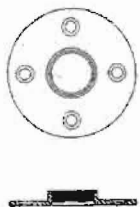

Flange
For Threaded 1 1/4" Tubing
No. FL125 ea.
For Threaded 1" Tubing
No. FL1 ea.

Zinc Plated Pipe Connectors

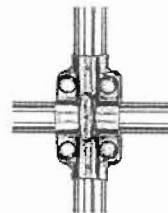

4-Way Connector
Connects 1" to 1" Tubing
No. ZC411 ea.
Connects 1 1/4" to 1 1/4" Tubing
No. ZC4125125 ea.
Connects 1 1/4" Tubing to 1" Tubing
No. ZC41251 ea.

Galvanized Tubing
1" Outside Diam.
No. GL-100
1 1/4" Outside Diam.
No. GL-AH746
See Page 23 for Prices.



Floor or
Ceiling Jack
with Flange
For 1 1/4" Tubing
No. ZCFL
ea.

**Cross-Brace
4-Way
Pipe Connector**
Connects two pipes
without making it
necessary to
cut either one of them.
Connects 1" to 1" Tubing
No. ZCB411 ea.
Connects 1 1/4" to 1 1/4"
Tubing
No. ZCB4125125
ea.
Connects 1 1/4"
to 1" Tubing
No. ZCB41251
ea.

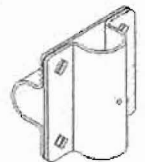

Industrial Shelving

Made of Steel In Grey Baked Enamel
Shelves - 20 gauge
Posts and Braces - 12 gauge

Available in a wide variety of widths, depths and heights. All units are re-usable - they are put together with Nuts and Bolts, and can be reconfigured to meet your changing requirements. Units shown here are just a few of the multitude of configurations with heights ranging from 3 feet to 14 feet. Call for more information and a FREE ON-SITE Estimate, to include delivery and installation.



Open
Starter Unit

5 SHELF UNIT
No. TS-2436/5
ea.

6 SHELF UNIT
No. TS-2436/6
ea.

7 SHELF UNIT
No. TS-2436/7
ea.

Additional shelves can
be added as needed.

PIECE GOODS

Industrial Units
(Not Shown)
30" D x 42" W x 99" H
2 units go back-to-back to
accommodate 60" rolls of
fabric.
Prices include 12-gauge
reinforcement bar for
extra support

STARTER UNIT

Includes:
• Sway Brace
• 5 Shelf Starter Unit
comprised of 2
back-to-back single
units
Each shelf is 24" apart
and includes front and
back reinforcements.
No. TS-3042/S
per unit

ADD-ON UNIT

No. TS-3042/Add
per unit

OPEN UNITS

prices include Back and
Side Braces
24" D x 36" W x 87" H

CLOSED UNITS

closed back and sides
These units are available
in sizes ranging from
12" x 24" to 42" x 48"

Closed
Starter Unit

Closed
Add-On Unit

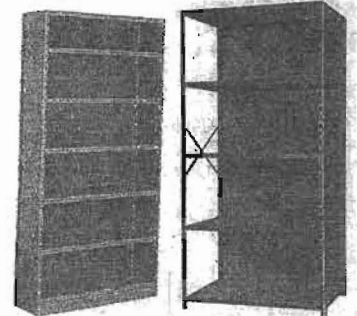

CLOSED UNITS

5-Shelf Starter Unit
24" x 36" x 87" H
No. TS-24365/CL
ea.

5 Shelf Add-On Unit
No. TS-24365/A
ea.

NOTE: Prices do not include delivery or installation.